

# TABLE OF CONTENT

## *Acknowledgement*

### PART ONE: INTRODUCTION

1. Rationale .....	1
2. Aim of study.....	2
3. Methodology of study.....	2
4. Scope of study.....	2
5. Design of study.....	3

### PART TWO: DEVELOPMENT

#### Chapter one: Theoretical background.....4

1. An overview in request.....	4
1.1 <b>What is request?</b> .....	<b>4</b>
1.2 <b>The role of request in communication</b> .....	<b>5</b>
1.3 <b>The use of request in languages</b> .....	<b>5</b>
2. Culture and communication.....	7
2.1 <b>The definition of culture and communication</b> .....	<b>7</b>
2.2 <b>Sociolinguistic researches about communication</b> .....	<b>7</b>
3. Cultural parameters.....	8
4. Context.....	9

Chapter two: The parameters that influence the use of English and Vietnamese request in communication at the office.

1. English request in communication at the office.....	11
<b>Requests depend on communicating mood.....</b>	<b>13</b>
<b>Requests depend on communicating attitude.....</b>	<b>15</b>
<b>Requests depend on communicating setting.....</b>	<b>16</b>
<b>Requests depend on communicating topic and content.....</b>	<b>17</b>
<b>Concluding remarks.....</b>	<b>18</b>
2. Vietnamese requests in communication at the office.....	19
<b>Requests depend on age.....</b>	<b>23</b>
<b>Requests depend on gender.....</b>	<b>24</b>
<b>Requests depend on relationship.....</b>	<b>24</b>
<b>Horizontal relationship.....</b>	<b>24</b>
<b>Compromising clash between age and social position in requests.....</b>	<b>25</b>
<b>Dynamic relationship.....</b>	<b>26</b>
<b>Family oriented relationship.....</b>	<b>28</b>
<b>Concluding remarks.....</b>	<b>28</b>

Chapter three: The context that influences the use of requests in communication at the office

1. Communicating at the first time meeting.....	30
<b>Communicating in business.....</b>	<b>30</b>
<b>Communicating in school and accademic field.....</b>	<b>32</b>
<b>Communicating in official politics.....</b>	<b>34</b>
2. Communication in daily meetings.....	34
<b>At business offices.....</b>	<b>34</b>

<b>The participants are age-equal.....</b>	<b>34</b>
<b>The participants are position-equal.....</b>	<b>35</b>
<b>The participants are at the same sex.....</b>	<b>36</b>
<b>At university.....</b>	<b>37</b>
<b>In formal communication.....</b>	<b>37</b>
<b>In informal communication.....</b>	<b>37</b>
<b>At political offices.....</b>	<b>39</b>
3. Concluding remarks.....	40
Chapter four: A case study of seminar for office staff.....	41
1.The reason for doing this case – study.....	41
2. Description of this case – study.....	41
<b>2.1 Order of the case –</b>	
<b>study.....</b>	<b>41</b>
<b>2.2 The content of the case –</b>	
<b>study.....</b>	<b>42</b>
3. Major findings.....	44
<b>3.1 Difference between English and Vietnamese request</b>	
<b>forms.....</b>	<b>44</b>
<b>3.2 Politeness in</b>	
<b>request.....</b>	<b>45</b>
<b>3.3 Implication for</b>	
<b>ELT.....</b>	<b>46</b>
4. Concluding remarks.....	48
PART THREE: CONCLUSION.....	49
1. Summary of the study.....	49

2. Suggested for further study.....50

References

*ACKNOWLEDGEMENTS*

**In the completion of this graduation paper, I have luckily received a great deal of assistance, guidance, supports and encouragement from my teachers, family and friends who have often been beside me. They have given me the great inspiration for me to complete this study.**

**First of all, I would like to express my sincere thanks to my supervisor – Mrs Nguyen Thi Hoa, MA who directly encouraged me and gave me suggestion on how to design the study and was always ready to give me necessary advice and idea, helpful comments as well as countless time of correction for this graduation paper.**

**Secondly, I would like to express my gratitude to Mrs Tran Ngoc Lien – The Dean of English department Who has greatly supported me in my research completion.**

**In conclusion, I would like to express my thanks to all the teachers in English Department, for their encouragement, teaching and guiding throughout my student time.**

# **PART ONE: INTRODUCTION**

## **1. RATIONALE**

It is widely known that English has been an international language, it has become a dominant language in many countries. With no exception of Viet Nam, the need and desire to acquire English has been increasing.

Studying and learning English is extremely interesting, it is more interesting to study the request forms in English as well as in Vietnamese. Requests are an interesting phenomenon on studying pragmatics. Each different culture has its own request forms. Therefore, in this graduation paper, I do expect to find out some meaningful ideas of requests in cross-cultural communication.

Moreover, many foreign investors recently have invested into Viet Nam, the foreign working environment makes Vietnamese staff have to acquire a good skill of English. One of the biggest difficulties is the way to request something politely and effectively in an English environment in Viet Nam. In general, Vietnamese staff can make request in communication with neutral couple addressing “ I-You” in foreign company to avoid the misusing the meaning of the request or being misunderstood each other. However, some foreigners want to use the right way which Vietnamese use to address in request. That is the reason why there are many troubles and misunderstanding in request in communication at the office, especially in foreign companies. Some of them may cause difficulty and even failure in communication as well.

In conclusion, this small research is conducted with the hope to indicate some of interesting findings in English and Vietnamese requests in communication at the office. This study may hopefully help office staff, students or learners of English can use as reference to avoid some troubles and get the best in communication at the office.

## **2. AIM OF STUDY**

Studying commonly use of request forms in English and Vietnamese in communication at the office.

Indicating some failures in communication at the foreign offices caused by misunderstanding or misusing the request forms.

Suggesting some correct use of request forms in the communication at the office. This study also aim at helping students or learners of English can use requests in communication more corectly and efficiently.

## **3.METHODOLOGY OF STUDY**

### **\*Quantitative method:**

Making tables of request forms, then collect the frequency they appear in real context, with the real relationship. The way of this method helps me much in understanding the request form which are used by both Vietnamese and foreign speakers in the real context. After getting the data and ideas, I will get some useful and interesting ideas about the trouble which foreigners face with and the reason for some culture shock when they make request in communication with Vietnamese.

**\*Qualitative method:** Giving the solution for the question “How to translate from English request into Vietnamese request in the real contexts?”.

\* **Formal and informal interview:** Giving the questions for Vietnamese and foreigner office staff at NamTieu shipbuilding industry corporation in Hai Phong city.

#### **4. SCOPE OF THE STUDY**

My research mainly focus on request forms in interlectural communication between English and Vietnamese.

Request forms are very flexible in language systems. There were many research about request form in many language such as: Contrastive analysis on requesting, politeness in request in English, the context for communication, the solidary in choosing request forms, the Cross - culture in English and Vietnamese request.

For restrict of the study, I just focus on researching the culture parameters and context that influence the use of English and Vietnamese request forms in communication at the office.

#### **5. DESIGN OF STUDY**

**Part one:** The rationale, aims, methods, scope and design of the rearch.

**Part two:** The development – the most importance part of this rearch. This part contain four chapters:

**Chapter one** is the theoretical background in which request forms and some related definitions are presented.

**Chapter two** presents some parameters that influence the use of English and Vietnamese request forms in communication at the office.

**Chapter three** is the part of the context that influences the use of English and Vietnamese request forms in communication at the office.

**Chapter four** is the seminar for office staff in Hai Phong city. This chapter presents the data to colligate the use of request forms in communication

at the office in real context. This chapter also proves the importance of cultural parameters and politeness in studying request forms.

**Part three:** The conclusion of the whole of this graduation paper. This part presents the summary as well as the orientation for further study.

## **PART TWO**

### **DEVELOPMENT**

#### **CHAPTER ONE: THEORETICAL BACKGROUND**

An understanding of intercultural communication is mainly related to an understanding of the ways in which the spoken and written word may be in intercultural communication typically choose a single language in which to communicate, individuals typically bring their own sociocultural expectations of language to the encounter. Speakers' expectations shape the interpretation of the meaning in various ways. To manage the interaction effectively, speakers need to be aware of the inherent norms of their own speech practices, the ways in which norms vary depending on situational factors and the ways in which speakers from other language backgrounds may have different expectations of language usage and behaviour.

In this research, some of the key ideas related to the study of request forms, culture, cultural parameters, context, communication and intercultural communication...are presented here and developed with more detail in the following chapters.

#### **1. AN OVERVIEW IN REQUEST**



## **1.1 What is request?**

Request is an act of politely asking for something, showing a need, a desire or a necessity to something. Its goal is to satisfy one's requirement. Request is carried out on a condition that there are at least two participants. Similar to command, request, in some circumstances, is an order, an act of telling somebody that they must do something. However, in command, the addresser frequently exercises absolutely a strong obligation and power over the addressee while request is more like a persuasion.

In addition, the reply for a command expected is an obey whereas that for a request is optional, either "yes" or "no". Therefore, request refers to a speech act more polite than command.

Sometimes, the boundary between command and request is absent as seen in the following examples:

*Have some more detailed*

or *Đồng chí nêu cụ thể hơn từng nhiệm vụ*

Particularly when command is expressed by a very high level of formality and politeness. "You are kindly requested not to make noise"

## **1.2 The role of request in communication.**

Each different culture has its own language and its own request forms. Some requests remain the solidary and equality in communication, some other requests separate age, sex, social position, attitude or mood of participants...

Requests in communication show a need, a desire or a necessary to something. Requests present someone must do somethings following the will of speakers.

## **1.3 The use of request in languages.**

Term of request can reflect a society's norms and values, and often provide information about speaker, such as age, gender, occupation, and social

status, as well as information about the relationship between the interlocutors, such as degree of intimacy, deference, social superiority, or level of solidarity.

In English, request can be divided into: three orientations and two levels:  
Formality & informality.

**\* Three Orientations:**

- **Speaker orientation**

*Could I have an apple?*

- **Listener orientation**

*Could you let me come in?*

- **Object orientation**

Object oriented requests are typically used in Restaurants, and shops where selling a couple of items. For example:

*The Sai Gon Times, please!*

*A hamburger, please!*

**\* Two levels:**

**Formality**

**Possibly:** *Could you possibly take me home?*

**Would you mind:** *Would you mind opening the door?*

**May / Might:** *May / Might I have a cake?*

**I wonder / I was wondering** *if I could have a day off?*

**Perhaps you would:** *Perhaps you would let me know when he comes back?*

**I should / would be very grateful** *if you let me know* Formality

**Possibly:** *Could you possibly take me home?*

**Would you mind:** *Would you mind opening the door?*

**May / Might:** *May / Might I have a cake?*

**I wonder / I was wondering** if I could have a day off?

**Perhaps you would:** *Perhaps you would let me know when he comes back?*

**I should / would be very grateful** if you let me know if you have any need?

**Would you like** to have my address?

**Would you be so kind enough** to give me a help?

### **\*Informality**

**Can:** *Can I have an icecream? (the most informal)*

**Couldn't / Can't:** *Can't you help me (complaint)*

**Tag question:** *You couldn't wait any more, could you? (not very hopeful)*

**Will you:** *Shut the door, will you? (more authoritative, less polite)*

**You will...won't you:** *You will call me, won't you? (Among friends)*

**You might:** *You might fax these for me (casual)*

In the following parts, these factor will be presented more clearly.

## **2. CULTURE AND COMMUNICATION**

### **2.1 The definition of culture and communication**

The term culture, as we will be using it, refers to the customs and expectations of a particular group of people, particularly as it affects their language use. In <http://vdict.com/> communication are defined as the connection allowing access between people or places. It is also the interchange information and ideas in verbal contact.

Communication is also defined as a process by which we sign and convey meaning in an attempt to create shared understanding. This process requires a vast repertoire of skills in intrapersonal and interpersonal processing, listening,

observing, speaking, questioning, analyzing, and evaluating. Use of these processes is development and transfers to all areas of life: home, school, community, work, and beyond. It is through communication that collaboration and cooperation occur. (<http://www.k12.wa.us/>)

## **2.2 Sociolinguistic researches about communication.**

There are two main groups of researches about communication: research on intercultural communication and research on cross – cultural communication.

Research on **intercultural communication** often relates to cultural groups at the level of nations and national languages; however, we need to be aware that many of the major languages of the world such as German, English, Spanish and Arabic are spoken by people of different nationalities, often in geographically distant areas and that each national variety of these pluricentric languages will have at least some of its own codified norms (Clyne 1992; Clyne, Fernandez & Muhr 2003). Intercultural communication is communication between members of different cultures. Intercultural communication involves differing perceptions, attitudes and interpretations. We know that even two people from the same culture can have communication problems. People can unintentionally hurt each other by something they say or do. Isn't it logical, then, that communication problems can be compounded among people who do not have the benefit of shared experiences (i.e. language and culture)?

Research on **cross – cultural communication** typically compares communication practices of one language / cultural group with another, while studies on intercultural communication focus on features of the shared communication between speakers from different language / cultural backgrounds.

Most modern research on cross-cultural and intercultural communication takes into account that communication is affected by different aspects of the

context, including cultural expectations, social relations and the purpose of the communication.

### **3. CULTURAL PARAMETERS**

The term parameter is any factor that defines a system and determines (or limit) its performance. Cultural parameters are cultural factors that define request forms in languages and determine (or limit) the use of those request forms.

There are many parameters that influence the use of request forms in communication such as age, sex, relation, communicating mood, attitude... These parameters will be presented in chapter two.

### **4. CONTEXT**

Context is the set of facts or circumstances that surround a situation or event. It also is the discourse that surrounds a language unit and helps to determine its interpretation.

Context-dependence of P (the power), D (the social distance), and R (the absolute ranking). Our social dimensions P, D, R can be viewed in various ways. Taking P as an extended example, we could argue that individuals are assigned an absolute value on this dimension that measures the power that each individual has relative to all others.

A more plausible view would be that power is a value attached not to individuals at all, but to role or role-sets. Thus in the role-set manager / employee, or parent / child, asymmetrical power is built in.

A third view would be that stable social valuations, whether of individual-P. Other situational sources of power may contribute to or adjust or entirely override such stable social valuations.

It is the last view that seems to us most adequate, even if it is the least definition suggestion. And we shall assume that situational factors enter into the values for P, D, and R, so that the values assessed hold only for S and H.

In studying the context of communication at offices, it should be the study of formal and informal, the first – time meeting and daily meeting communication. These studies will be presented in chapter three.

In addition, to study about request forms in English and Vietnamese we should pay attention to their language systems. English is one of Anglist where the objectivity and directness are highly mentioned. In this language system, the participants (“ego”) always try to mingle themselves into the context and consider their relationship with the surrounding in relation between subject and object. Besides that, the participants often express their ideas directly. While Vietnamese belong to Eastern – Asian language, in this system language the “ego” is dignified and directness can be equal to impoliteness.

**CHAPTER TWO**  
**THE PARAMETERS THAT INFLUENCE THE USE**  
**OF ENGLISH AND VIETNAMESE REQUEST IN**  
**COMMUNICATION AT THE OFFICE**

**1. ENGLISH REQUEST IN COMMUNICATION AT THE OFFICE**

It is said that English request forms is not very complicate, with using I – You we can easily to communicate with others, and we also easily show what we want others do, without the minding the difference in terms of age, sex, social position, mood of participants.... In fact, besides using I – You as neuter couple in our requests, it still exist multiple request forms, which present the different mood, attitude, setting, toppic and content. According to Austin: *“Communication in language is not only the way to indicate the informations but also the measure which aims at other purpuses”*.

In general, when making request, we need the action from H ( the people hear the request). In fact, The request suggest people do something without force or urge, but the willness of H. In addition, requests often contain some factors

which may cause impoliteness, thus, it is better to carefully make request, and make it politely, it also avoid to cause any trouble for H. For example:

*Will you close the door please?*

*( Anh sẽ đóng cửa chứ?)*

*( Xin anh / Anh làm ơn đóng hộ cái cửa lại đ- ợc không?)*

*Will you close the door please.*

*( Anh sẽ đóng cửa lại, xin mời.)*

*( Xin anh làm ơn đóng hộ cái cửa lại!)*

*Would you mind closing the window?*

*( Liệu anh có phản đối việc đóng cái cửa sổ không?)*

*Could I have your name of your company please?*

*( Anh cho biết tên công ty anh đi)*

*( Xin anh làm ơn nói cho tôi biết tên công ty anh là gì?)*

There fore, the ideas of Austin is reasonable, but it still extremmely depends on the relationship between Speaker and Hearer. In some cases, we should make requests like these:

**\* Request people to do things:**

*Would you mind signing this report?*

*Do you mind getting the dictionary?*

*could you mind getting the dictionary?*

**\* Confirming you will or can do it**

*Yes, of course/Certainly/Sure/Just a moment/Here you are.*

*I will sign it right away /I will get,do it right away*

**\* Asking for permission**

*Would you mind if I use your tellephone?*



*Could I use your telephone.?*

*Please do / yes, of course / certainly / well, actually it is out of order / I'm afraid it's out of order.....*

**\* Asking to talk to some one on the telephone**

*I'd like to speak to Mr. Tom, please.*

*May I speak to manager, please?*

*Could I speak to someone in the servise department, please?*

*Extension twenty- five, please.*

**\* Asking for an appointment**

*Do you think it would be possible for you / them to meet?*

*Do you think it would be possible to arrange a meeting?*

*Do you think it would be possible to arrange an appointment?*

*Could you fix an appointment for me with...?*

**\*Asking for more details at work**

*What would you like me to tall them?*

*How many would you like to order?*

*When would you like to talk to her?*

*By when would you like it completed/ finished?*

*What would you like to ask them?*

*I don't quite understand.*

*Could you explain it to me again, please?*

*Could you speak alittle slower, please? I'm afraid my English isn't very good.*

*Could you give me some more details? I'm afraid I don't have much experience with this.*

<b>ASKING</b>	<b>SAYING YES</b>	<b>SAYING NO</b>
Can I...?	Yes, please do.	I'm afraid...
Could I ...?	Of course.	I'm sorry but...
May I ...?	*Yearh, go ahead.	
	**Help yourself.	

\* In formal

\*\* Inviteing someone to take something.

### **1.1 English requests depend on communicating mood**

Likewise, a shift from one strategy to another may reflect the speaker's momentary " mood", not only as a function of the interaction and therefore as part of interactional balance, but completely extrinsically to interaction as well. Thus one day, you may look on all the worlds as your brother, treat all FTAs as small and regale everyone with positively polite effusions, the next day you may consider everyone your enemy and react to all contacts with the cold avoidences negative politeness. Such mood changes reflect a changed evaluation of D, P, and R. In an order for interactants to interpret utterances commonly they must have some assessment of each other's current mood. As such assessments build up over time, they enter into the interactants' assessments of one another's personality, and thus feed back into the basic interactional mutual knowledge estimations of D, P, and R.

That the idiosyncrasies of personality, the vagaries of mood, and the stabilities of social relationships might all be constructed ( at least in part) out of the same highly limited basic dimensions may seem improbable.

But there does seem to be potential for genuine ambiguity in interaction between these three orders of experience: If Loe jokes, is he jokey by nature, or he is in a jokey mood, or does he stand in a joking relationship with his interlocutor? Similar questions apply to the expression of intimacy, or of

respect. If this is so, it is a fundamental fact, and an understanding of significant dimensions on which personality is built, as well as social relationships. It suggests that an essential transactional or interactional theory of social life may provide a unified account of phenomena at such very different levels.

On anger or reproach, beside the use of lexical, semantic, and nonverbal modes, Americans also make requests with using addressing forms to express their attitudes. The change in the way of using name LN (Last name) into using TLN (Title with last name). Fasold (1990:25):

*“ Whenever they get angry with a person who they used to address by Last name, they will change into using Title with last name to express the gap or the interrupt in their relationship. Just after the problem is solved they change back to use the existed form ”.* Depend on mood of participants they use different addressing forms in request.

FN: First name

LN: Last name

TLN: Title with last name

<b>Mood</b>	<b>Forms of Address in request</b>
<p><b>Positive</b></p> <ul style="list-style-type: none"> <li>- Glad</li> <li>- Cheerful</li> </ul>	<ul style="list-style-type: none"> <li>- FN exchange (<i>Could you take me home, Dave?</i>)</li> <li>- Dear/honey (<i>Could you take me home, honey</i>)</li> </ul>
<p><b>Neuter</b></p>	<ul style="list-style-type: none"> <li>- FN/LN exchange (<i>Could you give me a sweet, Tom?</i>)</li> </ul>
<p><b>Negative</b></p> <ul style="list-style-type: none"> <li>- Sad</li> </ul>	<ul style="list-style-type: none"> <li>- FN exchange (<i>Anna King, lets go out!</i>)</li> <li>- TLN/T/you (<i>Professor Clinton, forgive me</i>)</li> </ul>

***Fig: Addressing forms depend on participants' mood in requests***

## 1.2 Communicating attitude

In common, the attitude of participants depends on their occupational and social position. Supervisors often be respected and admired so that subordinates should use nonreciprocal exchange TLN/FN to address in request to their supervisors. In that case, supervisor can use T/FN exchange to address themselves and their juniors. If the social position is equal addressing forms in requests can be used openly among all of these above forms, depend on what participants want to express in their communication. Forms of address in request depend on communication attitude can be expressed in the following table:

<b>Attitude</b>	<b>Forms of address in request</b>
<b>Positive</b>  1. Revere  2. High respect  3. Respect	- Nonreciprocal exchange TLN/T  - Nonreciprocal exchange T/TLN/LN  - Exchange LN/TLN/LN
<b>Neuter</b>	- Exchange LN/FN
<b>Negative</b>	T + diminutive name ( funny/joking name)

***Fig: Addressing forms depend on participants' attitude in request***

Sometimes, negative questions, which presume “yes” as an answer, are widely used a way to indicate that Speaker know Hearer wants, tastes, habits, etc..., and thus partially to redess the imposition of FTAs. For axample, for requests:

*Would you tell more detailed?*

*Don't you want some dinner now?*

or oppinions:

*Don't you think she should come?*

*Isn't it a beautiful vacation?*

### **1.3 Communicating setting**

In considering the setting of communication, the distance and familiarity are very important. Distance between managers and the people who work under them varies in different cultures.

In a country, where the managers are usually easy to talk to accessible and approachable and there is tradition of employees being involved in decision-making as part of a team of equals. This company managers and his/her subordinate can use the form LN exchange.

In other company where managers are usually more distant and remote, employees may feel quite distant from their managers and have a lot of deference for them: accepting decision but not participating in them. In that company, the environment seems so more hierarchical than it is in the above country, with more management layers so that forms of TLN/TFN/T are used frequently. As in daily communication, in business environment, the setting of communication also is divided into five settings: High formal/Formal/Normal/Informal/Really informal.

Forms of address in request depend on setting of communication can be shown in following table:

<b>Communicating setting</b>	<b>Forms of address</b>
<b>High formal</b>	TLN?FN exchange (title should mention the rank of position or participants' job)
<b>Formal</b>	Nonreciprocal exchange TLN/LN/FN ( title normally is Mr/Mrs/Miss/Ms.)
<b>Normal</b>	LN/FN exchange

<b>Informal</b>	LN/FN exchange
<b>Really Informal</b>	MNs

*Fig : Addressing forms depend on communication setting in request*

#### 1.4 Communication topic and content.

In daily communication topics for communicating are at five rates: High safe/Safe/Fairly safe/Unsafe/Really safe. Otherwise in business communication, topics there often are three first rates: High safe, safe and fairly safe.

Beside that, contents for business speeches often are the one which both speakers and hearers concern. So that we can draw a following table about communicating topic and content.

<b>Rate of communication topics (both of participants concern content)</b>	<b>Forms of address in request</b>
High safe	MNs
Safe	TLN/LN/FN exchange
Fairly safe	Nonreciprocal exchange TLN

In English, there is another form of address “ Address form avoidance-AFA” which sometimes is used in request. This form of address in Vietnamese is linked with negative value, especial when addressor is younger or lower positio than addressee. In fact, the use of this form in English is more frequent than that in Vietnamese. In Vietnamese, the use of this form just only in the scope among young people who are at equal age. However, in English, whenever participants do not know each other, they can use this form or even need not ues any addressing form, for example: “*Please open the windows!*”

It is also consider that the use of couple: “ I-You” is AFA, in request this couple is often used, additionally, this is one available way to address in making

request in special case in which participants do not know much together or they do not want to use TLN/FN...In fact, this couple seems encroach on all other addressing forms when we make request.

#### **1.4 Concluding remarks**

It is said that the request forms in communication at the office are not very complicate and open to any participants. Otherwise, the necessary of knowledge about how to use them effectively and politely is important for anyone who wants to make successful speeches.

There are many differences of culture in English as well as in Vietnamese, so that the way we make request in English is sometimes not the right way we make request in Vietnamese. Thus, We should carefully consider when making request in each situation to get the best effect and in order to avoid impoliteness.

Request forms depend on communicating mood, communicating attitude, communicating setting, communicating topic and content...They are variety and different, hence, we should not be little the use of English request forms, especially in International offices.

## **2. VIETNAMESE REQUEST FORMS AT THE OFFICE**

Like many other Eastern languages, forms of request in Vietnamese are very complex. As a matter of fact, the Vietnamese language has a complex system of person reference made up of dozens of request forms. Speakers assume particular positions of status or relationship by using these forms along with honorific markers and other expressions in their talk.

There are numerous ways of expressing requests in Vietnamese. They are ranged from formality, authority to closeness by variations of ages, social status and situations. Similar to English request, the variations are realized by lexical items, intonation and stress. Furthermore, the Vietnamese has its own typical characteristics, it is a wide choice of vocative personal pronouns, which interferes in discriminating meanings of requests.

### \* Formality

- Làm ơn : *Anh làm ơn chuyển giúp tôi tập tài liệu tới phòng kế hoạch?*

- Phiền : *Phiền chị gửi hộ em phiếu thanh toán này!*

- Vui lòng : *Anh vui lòng điền giúp em phiếu thăm dò này.*

- Nếu không bận/ Bớt chút thời gian/ tranh thủ:

*Nếu em không bận thì giúp chị kê cái bàn ra phía cửa sổ nhé.*

- Tag question:

Đ- ợc không/ có đ- ợc không

*Cô tìm cho tôi bản gốc của văn bản này có đ- ợc không?*

- Formal words: “ạ”

*Thứ bảy này sắp cho phép em nghỉ sớm đ- ợc không ạ?*

### \*Informality:

- **Formal words** : nhé/chứ/với

*Anh gọi giúp tôi taxi ngay nhé!*

*Cô đồng ý đến thực tế ở đó chứ!*

- **Without personal pronouns:**

*Đi uống n- ớc cái đã! (Sau giờ tan sở)*

In addition, in requesting, particularly when asking others for help, the Vietnamese often choose the ways to release the difficulties on the addressees, for example:

\* **Đễ thôi mà, ngắn thôi mà, nhanh thôi mà, một lát thôi...**

- *Giúp mình liên lạc với công ty đó nhé, nhanh thôi mà!*

\* **Persuasive:** Cố gắng đi

*Các anh ở lại làm thêm một lát nhé! cố gắng đi.*

In general, the Vietnamese prefer long expressions than the short ones in request. That is the reason why a lot of adjuncts are used so as to make requests



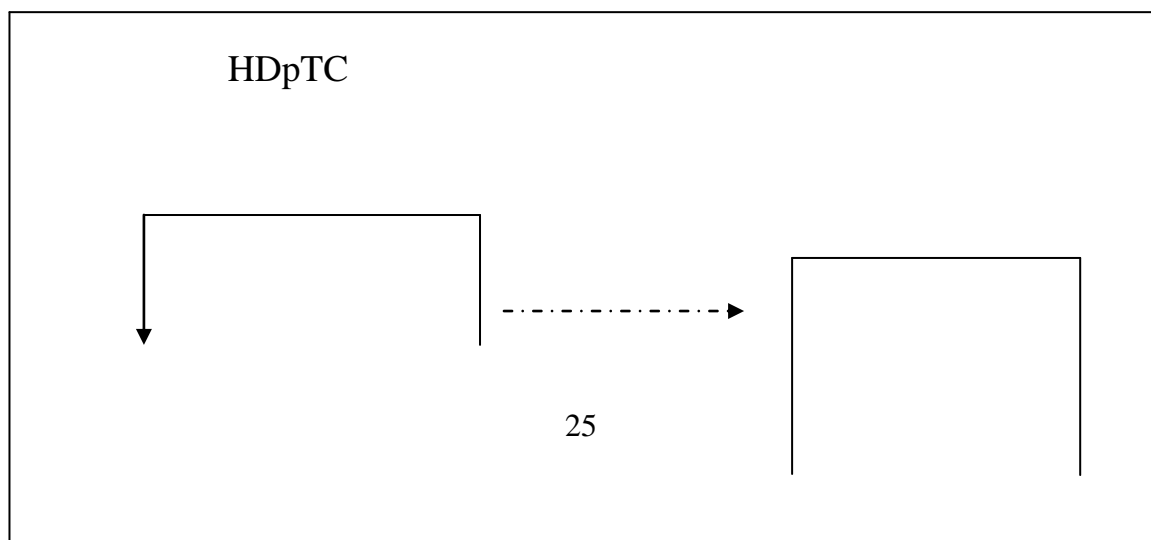
more convincing and acceptable. The final goal is “ to make the hearer follow the requirements” (DQB).

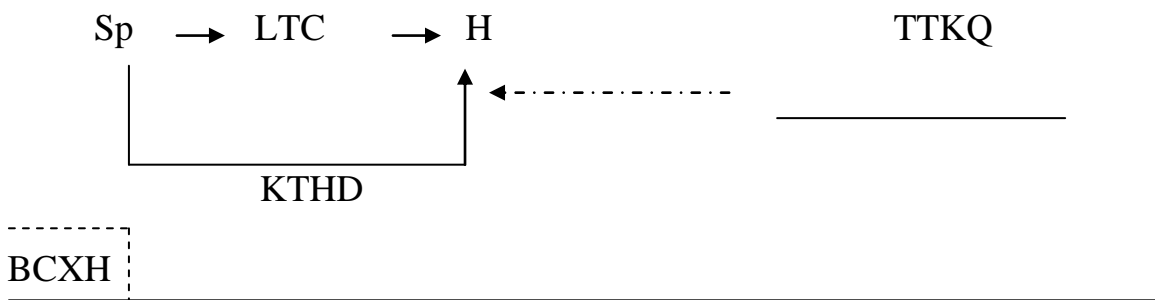
According to DQB, the boundary between request and command become disappear in sentences initiated with: “mời, xin, cần, nên. These can be seen as either a command or request command in this case is called Temporary command.

In communication at the office, Vietnamese request forms are very flexible. There are many relationship of terms in requests such as horizontal relationship, dynamic relationship, compromising clash between age and social position...However, in a contrastive analysis, I would like to mention the similarities and differences between English and Vietnamese. Hence, in this part, I would like to give a classification depending on which request forms express.

### **Request to receive information**

- Sp : Speaker
- H : Hearer
- KTHD : Action stimulating
- LTC : Request
- HDpTC : Reply for request
- TTKQ : The objective fact
- BCXH : Society context

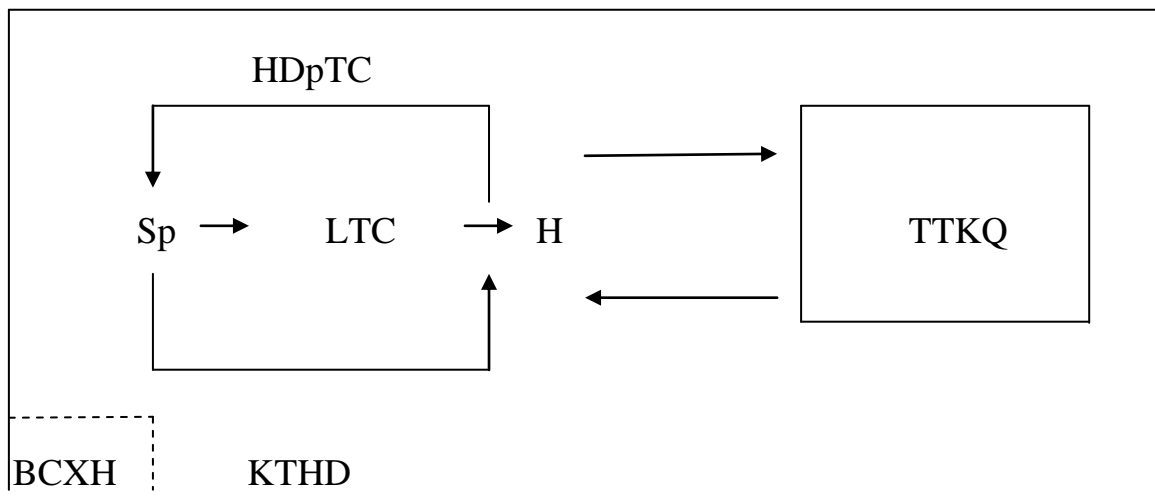




**Fig: Request to receive information**

It is the fact that, Request is always used in the specific communication context, and be affected by the society context, power distance, communication habits...between speaker and hearer.

**Request to get action:**



**Fig: Request to get action**

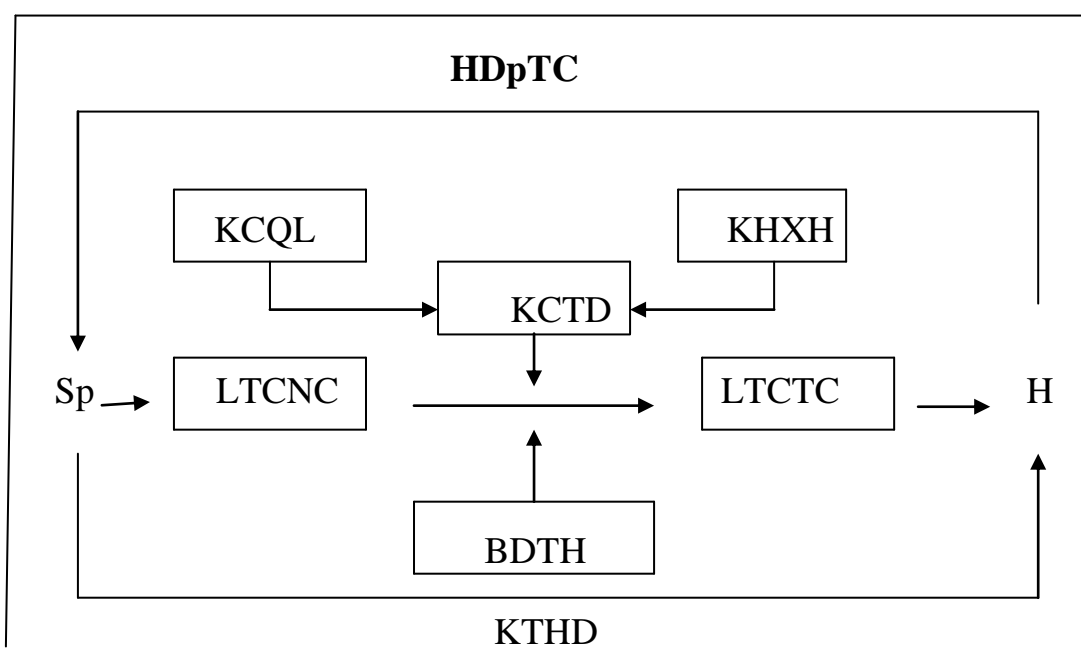
Request to get action is different from request to get information, Request to get action, Hearer has an effect on the real context by a physical strength. For example: (when hearing speaker requests):

“Close the door please!”

If hearer agrees, he will have to use a physical strength to do that action which Speaker asks. normally, in both English and Vietnamese, Request to get action often causes more troubles to hearer than request to get information.

**Pressure on request and reply**

HDpTCb	: Reply for request	LTCNC:	Request includes first grade
KCQL	: Power gap	LTCTC	: Request includes second grade
KCXH	: Society gap	KTHD:	Action stimulating
KCTD	: Relative gap	Sp:	Speaker
BDTH	: Situation change	H:	Hearer



***Fig: Pressure on request and reply***

In this kind of request, Speaker creates action stimulating to hearer through LTCNC; with the influence of two basic factors: relative gap - KCTD) (was created from power gap-KCQL and society gap - KCXH) and situation change -BDTH , thus Request includes second grade - LTCTC never creates any influence power to hearer, because all factors which act upon Request always change in terms of not only the different cultures but also in the same culture.

### **2.1. Request forms depend on age.**

As same as in English, The request forms among the younger person with others who are as old as their parents, the speakers should use polite request forms with the use of kinship terms as addressing forms. Normally, Vietnamese

always use “Con/ Cháu” in requests in front of elder person, then call their partners “Bác/Chú/Cô” – in the North of Viet Nam.

If speaker and hearer just have the gap of 1 - 9 years old, they can use the couple of “Anh - em” (For one/two male participant(s)) or “Chị - Em” (For one/two female participant(s)).

*Anh làm ơn cho em dùng nhờ máy fax với ạ!*

*Em có thể dịch giúp chị bản hợp đồng này ngay bây giờ không?*

If the speaker and hearer are equal in term of age, they can use these pair “Tớ - Cậu”, “Ta - Mình”, “Tớ - Bạn”, or “Tôi - Bạn”

*Chủ Nhật này tớ và cậu đi thăm Bác Liên nhé!*

*Tôi đề nghị bạn không hút thuốc ở đây!*

## **2.2 Request forms depend on gender.**

Because of the basic of feudal social rule, the Eastern culture, Vietnamese request forms still remain the gap between genders.

In Vietnamese thought, women seem at lower social position, that is why they always use the lower addressing forms in requests to address them selves in front of men. So that the couple of “ Anh – Em” usually appears in communication between male and female participants, especially in formal communication at the office.

## **2.3 Request forms depend on relationship.**

### **2.3.1 Horizontal relationship**

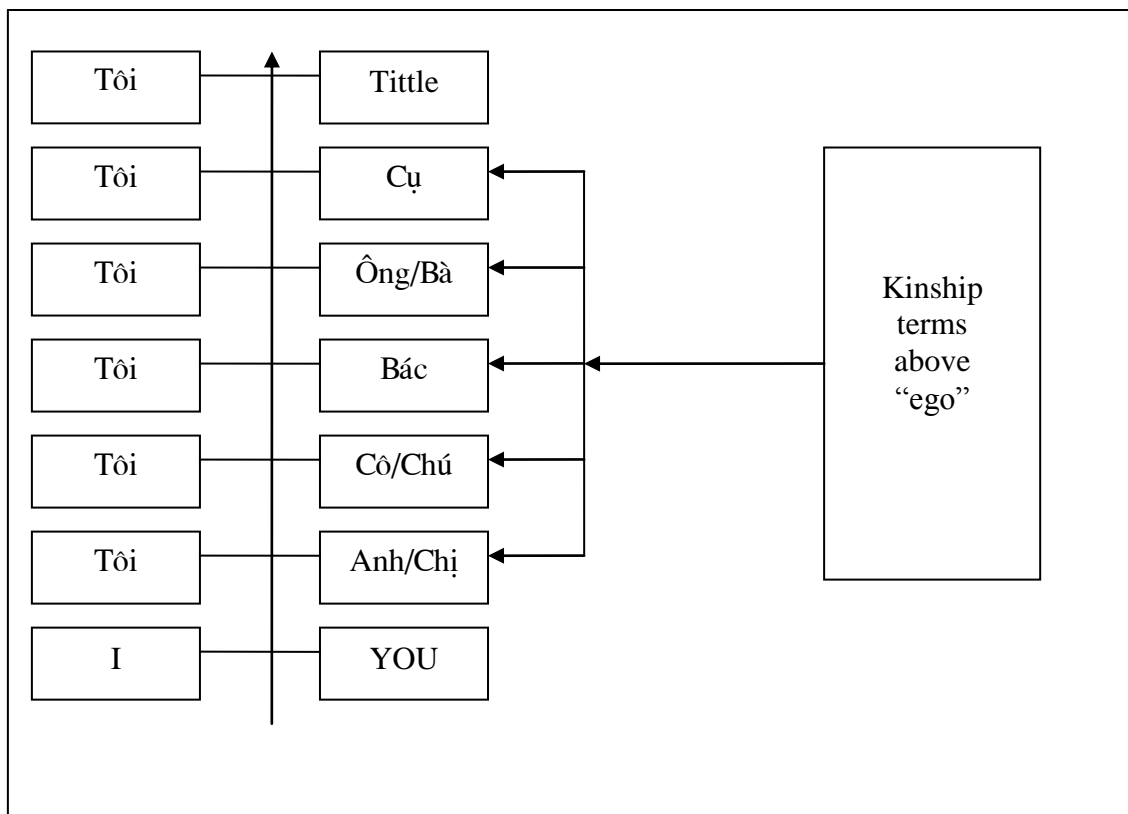
In the context of Request in communication at the office, Request forms are often in formal way, horizontal relationship is considered as same as the use of TLN/FN exchange when making request, because all couples in this relationship express the equality, insolidary, and formality.

*“...In considering the term of diachronic and etymology, these forms of address are not equal, because “Toi” means originally “subjects (for King)”*

and “Cụ, Ông/Bà, Bác, Cô/Chú, Anh/Chị” are all the kinship terms above “ego”. But in consideration of synchronic and pragmatics, these pairs are used simply to express the equality, insolidarity, polite and umobtrusiveness”.

It should be note that in Vietnamese request forms, although the kinship “Anh-Chị” in theory and consideration of the real rank of familiar relationship is at the lower position than “Cô/Chú” but in this kind of relationship and in the consideration of the effective of speeches which occur both “Tôi- Cô/Chú” and “Tôi-anh/Chị” the first pair seems less formal and more effective than the second pair. For example;

*Tôi đề nghị anh hãy nhắc kỹ tr- óc khi kí quyết định này !*



**Fig :Horizontal relationship in Vietnamese addressing forms**

*(Nguyen Quang, 2002: 167)*

**2.3.2. Compromising clash between age and social position in request forms.**

In Viet Nam society, The factor of compromising clash play an important role in request, if there is clash between age and social/occupational position (the elder has lower position), it is different form America society where the

social position plays an important role in giving decision for request forms, and Vietnamese will try to get compromising. The elder who has lower social position tends to address himself/herself by “Tôi” in request and then addresses his partner by title to express his/her respect, for example:

*Tôi mong thầy giáo quan tâm hơn nữa tới cháu!*

Then the younger who get higher social position can address himself/herself by “Tôi” and call his/her partner by “Bác/Chú/Cô/Anh/Chị” (depend on their age) at the same point to show his/her respect, for example:

*Tôi xin bác cứ yên tâm về việc đó!*

In the case of both speaker and hearer tend to get more colloquial, depend on the gap between their age, “Tôi” can be replaced by “Anh/Chị/Bác”, and title will be replaced by “Em/Cháu/Con” (with younger but at higher position), for example:

*Tôi mong lãnh đạo thông cảm cho hoàn cảnh của gia đình chúng tôi!*

*Bác mong cháu thông cảm cho hoàn cảnh của gia đình bác!*

The case of using kinship terms “Ông/Bà/Cụ” in request rarely occur here. In fact, the process of this tendency also is the process to change into relationship in Vietnamese request forms. It seems so similar to change from using TLN exchange into FN exchange in English addressing forms.

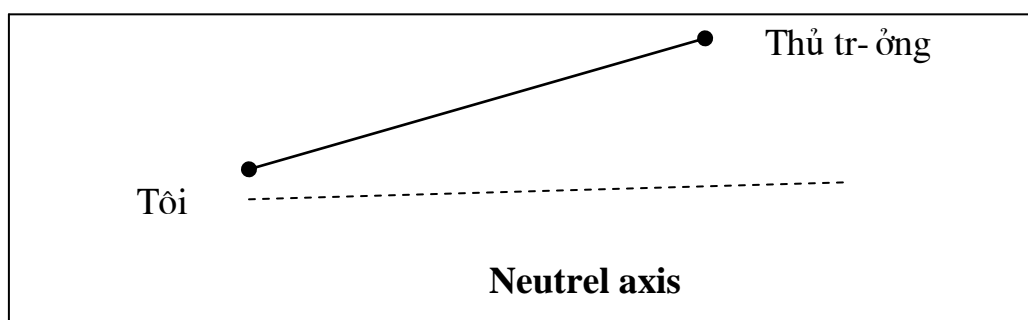
### **2.3.3 Dynamic relationship in Vietnamese request forms.**

The couple “Tôi -Title” in the relationship to compromise clash between age and social position in Vietnamese request forms can create another relationship, that is dynamic relationship. In Vietnamese cultural language, after a time of getting acquaintance, the participants in communicating can change their addressing forms in request from the couple of “Tôi -title” into the couple “Cháu/Em-title”, one face to express their self-abasement and solidarity, another face still keep their distance to their partner. For example:

( At first time work in a company, an official can say to his/her superior)

*Xin Thủ tr- ớng cho tôi hai ngày để hoàn thành báo cáo này ạ!*

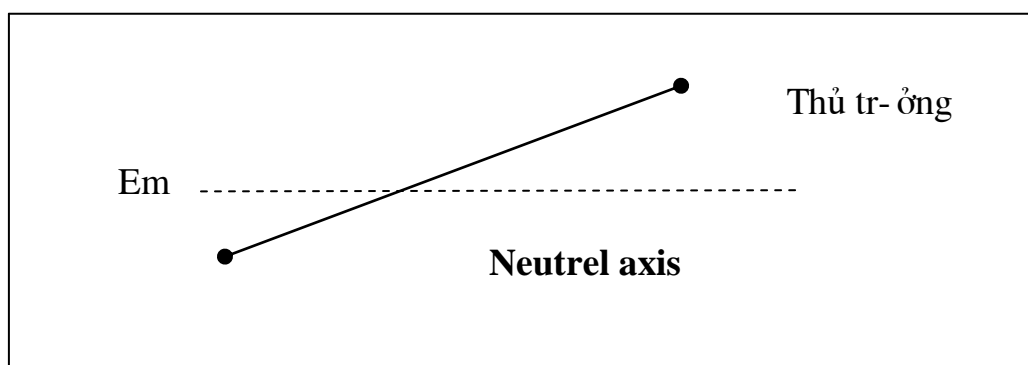
*Take me two days to finish this report, please!*



But in the next time, with the same request, this official can say:

*Xin thủ tr- ớng cho em hai ngày để hoàn thành báo cáo này ạ!*

*Take me two days to finish this report, please!*



In this modern life, this case happens manually. Many people used to pass the process of using “Tôi-title”, to use directly the couple “Em/ Cháu -title” to express the solidary and respect tho their superior. For axample:

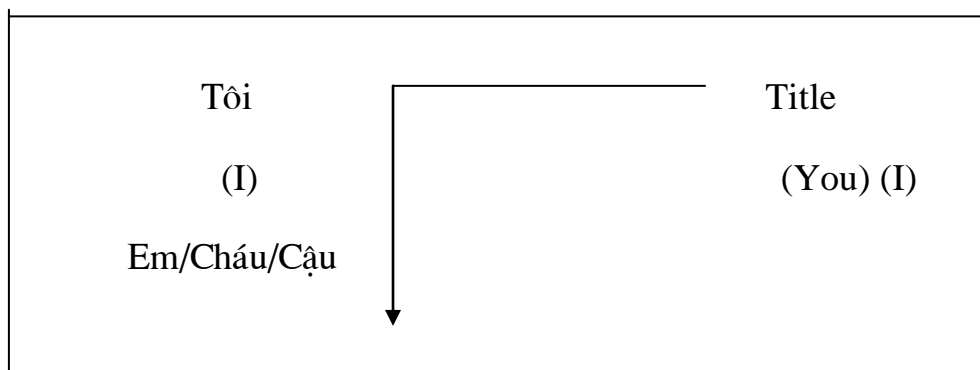
*Tôi xin phép thủ tr- ớng cho tôi đ- ợc nghỉ hai ngày để chăm nom bà cụ!*

*Em mong thủ tr- ớng cho em nghỉ hai ngày để chăm nom bà cụ!*

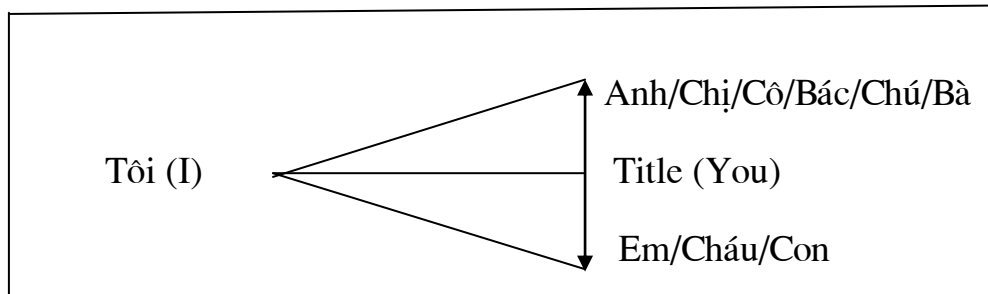
*I would like to have 2 days off to take care of my old mum, please!*

It is as same as the change from using TLN exchange into the use of FN exchange. The difference here is: in English, the person who starts the change in

addressing often is the one who has higher position, while in Vietnamese the starter can be both the person who has lower position or higher position. This dynamic relationship can be express in the following chart:



In dynamic relationship also conclude the couple in which “Tôi” is keep but title is changed. In this case, the title of speaker often is at low position. So in this case, title often is changed into “Em/Cháu” or “Anh/Chị/Cô/Bác/Chú”. And this case of dynamic relationship can be expressed in the following chart:



### 2.3.4 Family-oriented relationship

Family-oriented relationship is special case in vietnamese request forms, in which people make request with addressing on behalf of their children.

The 1<sup>st</sup> person still adress himself/herself as in circular relationship but call the 2<sup>nd</sup> person in the way his/her children can use in circular relationship. In fact, this form of adress in request is used in really informal context.

### 2.4 Concluding remarks



In fact, in some other languages (not only Vietnamese), the use of request forms are very complicate. Hence, under any circumstance and in any social relationship, participants should try their best to find rank out himself/herself and his/her partner, use the factor of relative, social position, age, sex...to find out available request forms, to practise effectively and reasonably.

In considering of age, gender, and relationship (Horizontal relationship, compromising clash between age and social position in request, dynamic relationship and family-oriented relationship) we can make request in order to get the best result and it is still polite and never cause troubles for hearer, that is the most important thing we should care when giving request in any circumstance.

## CHAPTER THREE

### THE CONTEXT THAT INFLUENCES THE USE OF REQUEST IN COMMUNICATION AT THE OFFICES

In English, when making request, it is easily to use the pair I-You as addressing without breaking down the communication, but there is a fact that how to translate for Vietnamese that pair in real context. This chapter also shows some factors that lead to culture-shock in communication when foreigners use Vietnamese to contacts with other native speakers. For the restricted of this paper, I just focus on the context that influences the use of request forms in communicaton at the office.

#### **1. Communicating at the first time meeting**

For the first time meeting, in both English and Vietnamese, The request forms are often in really formal ways. In fact, in English they always use Tittle with last name to address participants just at the first point of time, after that, they turn back to use the pair I-You to adress in request forms. In Vietnamese, during the first time communication, when showing request, they keep addressing participants with the really formal terms of address.

#### **Communicating in business**

*S: Good morning, Mr John. I am Sopa Clinton. I am the new secretary.*

*J: Good morning. Welcome to Graphic, Mss Clinton. How can I help you ?*

*S: Thank you, Mr John. Could you show me where is my desk, please?*

*J: Your desk is over there on the right*

*S: Right.*

In this case, the interpreter must try to guess the age of participants. If Mr John is older than Mss Sopa, the translating should be:

*S: Xin chào ông John, tôi là Sopa Clinton, tôi là th- kí mới.*

*J: Xin chào cô Clinton, hoan nghênh cô đến với Graphic, tôi có thể giúp gì cho cô nhỉ?*

*S: Xin cảm ơn Ông John, Ông làm ơn chỉ cho tôi biết bàn làm việc của tôi ạ!*

*J: Bàn làm việc của cô ở đằng kia bên phải.*

*S: Vâng.*

In the case Mss Sopa and Mr John are at the same age or even Mr. John is younger than Mss Sopa, in formal way, the translating should be:

*S: Chào anh John, tôi là Sopa Clinton, tôi là th- kí mới.*

*J: Chào cô Sopa, hoan nghênh cô đến với Graphic. Tôi rất sẵn lòng giúp cô.*

*S: Xin cảm ơn anh, anh có thể chỉ cho tôi bàn làm việc của tôi đ- ợc không ạ?*

*J: Bàn làm việc của cô ở đằng kia bên phải.*

*S: Vâng.*

During the conversation at the first time meeting, after greeting, when speaker want to give any request, he always keeps the pair of “Ông-tôi, cô-tôi, anh tôi, chị- tôi” to address in request.

But when they are in really high occupational position in business office, the Vietnamese request forms should be changed into really high formal with the pair of “Ngài/Ông-Tôi, Cô-Tôi”. For example:

*T: Good morning, Kanjana.*

*K: Good morning, sir.*

*T: Could you please hold my calls this morning? I will be very busy.*

*K: Certainly, sir. I will do it right away.*

*We can translate like this:*

*T: Xin chào Kainjna.*

*K: Xin chào ngài.*

*T: Cô vui lòng tiếp các cuộc gọi của tôi sáng nay nhé. Tôi sẽ rất bận.*

*K: Th- a ngài chắc chắn đ- ợc ạ, tôi sẽ làm ngay.*

### **. Communicating in school and academic field.**

It is known that the communicating in school and in academic field is the using with the pair: “I – Teacher/ Professor. Thus, someone will get surprise when I am going to mention about the communication at school and academic field. But in fact, during the semester meeting between teachers and students, the communication is often high formal in any circumstance. But in other meetings when participants who met many times and knew each other well, the way to make request can be changed, for example:

*Student: Good morning, teacher!*

*Teacher: Good morning! All of you finished home work, didn't you?*

*Student: Yes!*

*Teacher: Now, tell me the main content of last lesson.*

We can translate into Vietnamese as:

*Sv : Chúng em chào cô ạ!*

*Cô giáo : Cô chào cả lớp! Các em đã hoàn thành bài về nhà rồi đúng không nhỉ?*

*Sv : Vâng th- a cô.*

*Cô giáo : Giờ các em hãy nói cho cô biết nội dung của bài tr- ớc nào.*

*This is another way to translate into Vietnamese:*

*Sv : Chúng em chào cô!*

*Cô giáo : Chào cả lớp! Cả lớp đã làm hết bài về nhà ch- a?*

Sv : *Vâng ạ!*

Cô giáo : *Nào, hãy cho biết nội dung của bài tr-ớc!*

But for other meetings between other participants who are from different school but at the same rank of position, for example: (The context is the first time meeting between two headmasters from Hanoi National University and Hue University):

A: *How do you do, Pro. Ly.*

B: *How do you do, Pro. Tran.*

A: *Could you please hold a meeting next week!*

B: *It is my pleasure, sir.*

This short conversation can be translated:

A: *Kính chào ngài, giáo s- Lý.*

B: *Hân hạnh chào ngài, giáo s- Trần.*

A: *Ngài có thể tổ chức buổi họp vào tuần tới không th- a ngài?*

B: *Tôi rất sẵn lòng th- a ngài.*

Another example is about the first time meeting between a person who has higher position in academic field (The Dean of a University department) and one other (a staff of a University department)

A: *Good morning, Ms Nga!*

B: *Hello, Ms Diem.*

A: *My baby has been sick, I would like to have 2 days off, please!*

B: *Really? It is ok, you should come home early.*

In this case we can translate into Vietnamese:

A: *Em chào cô, cô Nga*

B: *Chào em, có việc gì thế?*

*A: Th- a cô, con em bị ốm suốt, em mong cô cho em nghỉ 2 ngày để chăm nó.*

*B: Thế à ? Đ- ợc rồi, em về sớm đi.*

### **1.3. Communicating in official politics.**

It must be recognized that in official politics, forms of request should be at high formal usage. In this context, both speaker and listener have to carefully consider when giving any request, to get the best effect in communication. In this case the request forms must be high formal.

For example, here is the meeting between American President B. Obama and Viet Nam prime Minister Nguyen Tan Dung:

*D: Good morning, Mr Obama!*

*O: Good morning, Mr Dung!*

*D: Could you show us your ideas about Iraqi war?*

*O: Yes, of course sir, it is my please.*

In translation into Vietnamese, it should be:

*D: Hân hạnh đ- ợc gặp ngài, ngài Obama.*

*O: Hân hạnh chào ông, ông Dung.*

*D: Th- a ngài, ngài có thể đ- a ra vài ý kiến của ngài về cuộc chiến tranh Irac?*

*O: Vâng, tôi rất sẵn lòng th- a ông.*

## **2. Communicating in daily meeting.**

In daily life, request forms should be in informal usage. In this kind of communication depend on age, sex, social raltionship... Request forms in each situation should be distinguished. In different contex this distint can be different.

### **2.1. At business offices.**

#### **2.1.1. The participants are age – equal.**

In the situation of participants are age – equal, the factor that decides request forms in communication is the social position.

**- The communicating between a superior and a subordinate, who have the same sex:**

*A: Lets pay for this month's tax, Lam!*

*B: Yes, of course.*

*A: Then can you supply all documents last week for me?*

*B: Yes, I will do it right now.*

The translation should be:

*A: Lam ơi, thanh toán tiền thuế tháng này đi nhé!*

*B: Vâng th- a chị.*

*A: Sau đó hãy đ- a cho chị tất cả tài liệu của tuần tr- ớc nhé!*

*B: Em sẽ làm ngay đây.*

**- The communication occurs between a superior and a subordinate, they are different sex.**

*A: Ms Ha, take the copy of these papers please!*

*B: Yes, Where should I put them, Mr Nam?*

*A: Let them in the desk over there, please!*

*B: Yes, certainly.*

The translation should be:

*A: Cô Hà, photô giúp tôi những giấy tờ này nhé!*

*B: Vâng, tôi để chúng ở đâu hả anh Nam?*

*A: Cô để ở cái bàn phía đằng kia hộ tôi nhé!*

*B: Vâng, đ- ợc rồi.*

**2.1.2. The participants are position – equal.**

**- The communication occurs between two people who have the different sex, but they are position equal and age equal.**

*A: Could you send some of our brochures to Mr. Waits from the Seaside Hotel? He is a very good friend of mine.*

*B: Well, actually, we are all out of brochures, sir.*

*A: Can you order some right away, Keny? It is quite important.*

*B: Certainly, sir. I will do it right away.*

This conversation can be translated into Vietnamese:

*A: Chị gửi một số tờ thông tin quảng cáo tới ông Wats ở khách sạn Seaside nhé, ông ấy là một người bạn rất tốt của tôi đấy.*

*B: A nh- ng mà chúng ta đã hết các tờ thông tin quảng cáo rồi.*

*A: Cô có thể đặt ngay một số đ- ợc không, Keny? Rất quan trọng đó!*

*B: Tất nhiên, tôi sẽ làm ngay.*

**- The conversation between the old man and young woman:**

*A: Could I have the Olympia report now?*

*B: I'm afraid Mss Sopa is still working on it, sir. She should be finished with it in about an hour.*

*A: Hmm, I see. Can you get it to me right away when it is ready?*

*B: Yes, of course.*

The translation for this conversation should be:

*A: Bây giờ đ- a cho bác bản báo cáo Olympia đ- ợc không?*

*B: Cháu e là Sopa vẫn còn đang làm nó. có lẽ khoảng một tiếng nữa cô ý sẽ xong ạ.*

*A: Ừm bác hiểu rồi, đem cho bác ngay khi đã xong nhé!*

*B: Vâng, th- a bác.*

**2.1.3. The participants are at the same sex:**



Here is the conversation between an old superior and young subordinate at the office:

*A: Tom, do you know this word?*

*B: This word...? Oh, I am sorry. I forget it.*

*A: Can I borrow your English dictionary for a while?*

*B: Yes, never mind, sir.*

*A: How lucky, thanks.*

In Vietnamese we say:

*A: Tom này, cháu có biết nghĩa của từ này không nhỉ?*

*B: Từ này ạ...? Cháu xin lỗi, cháu quên rồi.*

*A: Cho chú m- ơn từ điển Tiếng Anh của cháu nhé!*

*B: Vâng, không có gì đâu ạ.*

*A: May quá, cảm ơn cháu.*

## **2.2. At university.**

As what I presented before, Request forms at university and in academic field seem unchange, but in fact they can be different. In considering the choice of Request forms, conversations are constructed among staff or between teachers and students.

In this part, I particularly mention about formal and informal communication at University.

### **2.2.1. In formal communication**

#### **\* Conversation between a lecturer and a student.**

In Vietnamese, the request forms in communication between a teacher/lecturer and a student is quite formal. They use the pair of “Thầy/Cô giáo- Em” or “Giáo sư - Em” These pairs are quite similar to the pairs “I - Teacher” or “I-Professor” in English.

*A: Everybody, pay attention please!, You should hand in your paper test in 45 minutes.*

*B: Professor Janet, Could I hand in my paper after my finishing, please!*

*A: It is ok.*

The translation should be:

*A: Cả lớp chú ý này, các em sẽ phải nộp bài sau 45 phút nhé!*

*B: Th- a cô Janet, Em có thể nộp bài ngay khi em làm xong không ạ?*

*A: Thế cũng đ- ợc em ạ.*

**\* Conversation between an old lecturer and the Dean of University department:**

*A: Professor Manh, could you take part in the next seminar about environment population?*

*B: Certainly, I could.*

The translation should be:

*A: Thầy Mạnh à, thầy có thể tham gia buổi hội thảo về bảo vệ môi tr- ờng tới không ạ?*

*B: Chắc chắn tôi sẽ tham gia.*

This is another way of translation:

*A: Đồng chí Mạnh ạ, đồng chí có thể tham gia buổi hội thảo về bảo vệ môi tr- ờng tới không ?*

*B: Vâng, tôi sẽ tham gia.*

### **2.2.2. In informal communication.**

In this situation, I would like to mention about the communication between the staff in the University. (Which I presented in the part of 1.2)

Additionally, here is the conversation between two students in informal communication.

*A: Nam, can you turn off the fan? You see Mai got a cold.*

*B: Never mind!*

*A: Can you take Mai home after finishing our lesson?*

*B: Yes, I am ready!*

And the translation for this conversation could be:

*A: Nam à, bạn có thể tắt quạt đi không? Bạn thấy đấy Mai bị cảm lạnh.*

*B: ừ, không sao đâu.*

*A: Sau giờ tan học bạn đi- a Mai về nhà nhé!*

*B: Tớ rất sẵn lòng.*

### **2.3. At political offices:**

At political office, or in army office, the request forms are often in formal way. Sometimes, they are different and change. In this field, when making request, people often use the form of addressing “Tôi- Đồng chí” or “Bác/Anh/Chị/Chú - Tôi”. For example:

*A: Good morning, sir!*

*B: Good morning, Thang.*

*A: May I submit my training report now, please?*

*B: That sound good, well give me!*

*A: Here you are, sir.*

*B: Could you tell me about your oppinion?*

*A: Oh, let me see, you do a good job, Thang!.*

*B: Thanks, sir.*

The translation may be:

*A: Em chào thủ tr- ớng.*

*B: Chào đồng chí Thắng.*

*A: Th- a thủ tr- ởng tôi có thể nộp bản báo cáo thực tập ngay bây giờ không ạ?*

*B: Ô đ- ợc đấy. Đồng chí đ- a tôi xem nào.*

*A: Xin mời Thủ tr- ởng xem ạ.*

*B: Để tôi xem nào, đồng chí làm tốt đấy.*

*A: Em cảm ơn thủ tr- ởng.*

*Another case we can say:*

*A: Em chào anh ạ.*

*B: Chào chú.*

*A: Anh ạ, em có thể nộp bản báo cáo thực tập ngay bây giờ?*

*B: Ô đ- ợc đấy. Chú đ- a tôi xem nào.*

*A: Đây anh xem đi ạ!*

*B: Để tôi xem nào, chú làm tốt đấy.*

*A: Em cảm ơn anh.*

### **3. Concluding remarks**

In this part of my graduation paper, I particularly aim to find out the answer for the question “How to translate English request forms in to Vietnamese request forms in the real contexts?” The notes for any succeed translation are:

- Be careful in guessing the partner in terms of age, gender, social position...
- Revolve the context in mind.
- Pay attention to forms of communication.
- Consider the mood and attitude of participants in the real contexts.
- Keep in mind flexible Vietnamese request forms.

This chapter can help learners of English or people who speak English as the way to communicate can avoid breaking – down communication by foreigners.

## **CHAPTER FOUR**

### **A CASE STUDY OF SEMINAR**

#### **FOR OFFICE STAFF**

#### **1. The reason for doing this case - study.**

We all know that Request forms in both English and in Vietnamese are quite complex, the two above chapters, I have presented the use of English request and Vietnamese request. When the communication happens in the real context, the request which is used is various and sometimes lead to misunderstand. Thus, in this case-study, I would like to give some situations for office staff who work in Nam Trieu Shipbuilding industry corporation ( both Vietnamese and foreigner staff), will deal with each situation and show their own ideas.

After that I will point out some differences as well as similarities in English and Vietnamese Request in practical use.

#### **2. Description of the case – study**

In this seminar, I examine language choices made in Nam Trieu shipbuilding industry corporation where the staff and engineers are different nationalities such as: Chinese, English, Swedish, Vietnamese... Even they own their own mother languages, they still use English as an international language to communicate at work. Most of them often wonder how to make request politely and efficiently? That is the question I would like to answer in this chapter.

##### **2.1 The order of the case – study**

At first I give the list of request forms in each situation to 15 staff there, they are both Vietnamese and foreigner staff, they sometimes use English to communicate, they give the answers and opinions about request in English and in Vietnamese.

In this case study, I only show 4 popular responses for each situation, because some of them give some common responses. After that, I collect the data, their ideas and get the major findings. In this part, try to focus on:

*\* The Difference between English and Vietnamese request forms.*

*\* Politeness in request.*

*\* Implication for ELT (Design some activities for teaching).*

## 2.2 Contents of Case – study.

Situation	Vietnamese	English
<b>1. Ask your colleague to help you to move the heavy machine.</b>	<ul style="list-style-type: none"> <li>- Anh có thể giúp tôi chuyển cái máy này không?</li> <li>- Anh giúp tôi chuyển cái máy này nhé?</li> <li>- Anh có bận gì không giúp tôi chuyển cái máy này với!</li> <li>- Anh giúp tôi chuyển cái máy này thì tốt quá!</li> </ul>	<ul style="list-style-type: none"> <li>- Could you help me to move this machine?</li> <li>- Could I have your help to move this machine?</li> <li>- Would you mind helping me for moving this machine?</li> <li>- I should be very grateful if you help me to move this machine.</li> </ul>
<b>2. Ask the clerks to turn down his radio.</b>	<ul style="list-style-type: none"> <li>- Anh vặn nhỏ cái đài hộ nhé!</li> <li>- Phiền anh vặn nhỏ cái đài nhé!</li> </ul>	<ul style="list-style-type: none"> <li>- Will you turn down your radio?</li> <li>- Would you mind if you turn down your radio?</li> </ul>

	<ul style="list-style-type: none"> <li>- Anh vặn nhỏ cái đài lại đ- ọc không?</li> <li>- Anh vặn nhỏ cái đài tí chút nhĩ?</li> </ul>	<ul style="list-style-type: none"> <li>- Turn down your radio, please?</li> <li>- Could you possibly turn down your radio?</li> </ul>
<p><b>3. Ask an accountant to get you the balance sheet.</b></p>	<ul style="list-style-type: none"> <li>- Cho em lấy phiếu thanh toán nhé?</li> <li>- Chị cho em lấy phiếu thanh toán giờ thì tốt quá!</li> <li>- Em lấy phiếu thanh toán đ- ọc không?</li> <li>- Phiền chị cho em lấy phiếu thanh toán nhé!</li> </ul>	<ul style="list-style-type: none"> <li>- May I have the balance sheet?</li> <li>- Would you be so kind enough to give me the balance sheet?</li> <li>- Can I have the balance sheet?</li> <li>- Would you mind giving me the balance sheet?</li> </ul>
<p><b>4. Ask your colleague to pass the paper.</b></p>	<ul style="list-style-type: none"> <li>- Phiền anh chuyển hộ em tờ giấy với!</li> <li>- Đ- a hộ em tờ giấy với!</li> <li>- Anh làm ơn chuyển hộ em tờ giấy nhé!</li> <li>- Làm ơn đ- a cho em tờ giấy nào!</li> </ul>	<ul style="list-style-type: none"> <li>- Would you mind passing me the paper?</li> <li>- Pass me the paper please?</li> <li>- I wonder If you could pass me the paper?</li> <li>- Could I have the paper, please?</li> </ul>

<p><b>5. Invite your colleague to take a party.</b></p>	<p>- Đến dự buổi tiệc với mình nhé!</p> <p>- Không biết anh có thể dự buổi tiệc đó không nhỉ?</p> <p>- Anh sẽ đến buổi tiệc của em chứ?</p> <p>- Bạn có thể đến buổi tiệc của mình chứ?</p>	<p>- Could you take a party with me?</p> <p>- I wonder If you could come to that party?</p> <p>- Might you come to my party?</p> <p>- Would you possibly take my party?</p>
---	---	---

### 3. Major findings

#### 3.1 Difference between English and Vietnamese request.

First of all, we can see that the number of clauses used in each utterance in each situation is quite similar in two languages:

May I have the balance sheet?

Làm ơn cho em xin tờ phiếu thanh toán!

However, number of words in each utterance differentiates from each other. English sentences tend to be shorter than Vietnamese ones, though they carry the same meaning. It is obvious that Vietnamese prefer long expressions than the short ones in social interaction.

The list of five situations and 20 utterances show a great difference between English culture and Vietnamese culture in terms of addressing form. On the whole, the Vietnamese addressing forms are complicated, which are classified by age, social status, relationship and level of friendship. In fact, the Vietnamese tend to use horizontal relationship in both extending and encountering a request. The way Vietnamese people address considerably



contributes to make their requests more polite, at the same time, show their respect to others. On contrary, English people are absolutely simple, only “I-You” are used, the English never use circular relationship in their addressing forms, thus it is impossible to find a gap of age when the English address. However, the politeness and respect in their requests can be felt from their using formal language such as “Could you possibly, sorry to trouble you, if you don’t mind, please...”

Obviously, the Vietnamese may have little difficulty in making requests with using appropriate addressing forms when they communicate with the native English while it poses a considerable problem for the English to understand and use accurately addressing forms in their requests.

### **3.2 Politeness in request**

In this case - study, I focus on studying two kinds of redressive actions, those are: Positive politeness and negative politeness.

\* **Positive politeness** which is mainly used to narrow the distance between S and H, and enhance their solidarity.

Positive politeness strategies are usable not only for FTA redress but in general as a kind of social accelerator, where S, in using the, indicates that she/he wants to “come closer” to H. In theory, positive politeness strategies are generally preferred by the Vietnamese and sometimes may cause culture shock with typical concerning questions in Vietnamese, that are considered inappropriate in American culture.

There are some positive politeness strategies used in making requests, which are available in English and quite common in Vietnamese:

- Claim in-group solidarity
- Show S’s concern to H
- Be optimistic

- Give (or ask for) reasons

\* **Negative politeness** which is understood as a concern not to impose upon others or restrict their freedom, but remain distance. While positive politeness narrows the distance between interlocutors, negative politeness keep a distance between them.

Negative politeness strategies is essentially avoidance-based, and the realizations of negative politeness strategies consist in assurances that S recognizes and respects H's negative face wants and will not interfere with H's freedom of action.

Negative politeness strategies used by the informants include:

- Hedge
- Be pessimistic
- Minimize the imposition
- Give deference
- Go on record as incurring a debt, or as not indebted H
- State the FTA as a general rule
- Nominalize
- Personalize S and H

In this case-study, there are many differences and some similarities which prove to be influenced by complex social-cultural factors such as: age, gender and familial relationship; relative power between S and H; the topics and the situations in which requests are made.

As stated by many American informants *“Westerners don’t care as much about the age, sex, or familial relationship of their interlocutor as Asians do”*. Perhaps, it can explain why the percentage of negative politeness use of the Vietnamese informants is higher than that of their English counterpoints.

Hence, politeness is a speech act threatening the hearer’s face, in order to avoid communication conflicts, cross-cultural miscommunication, and communication breakdown, the language learners must have good communicative competence (how this language is used in a specific socio-cultural context) beside having linguistic competence ( the knowledge of phonology, grammar, and vocabulary of language).

### **3.3 Implication for ELT**

*“If we teach language without teaching at the same time the culture in which it operates, we are teaching meaningless symbols or symbols to which the SS attach the wrong meaning; for unless he is warned, he receives cultural*

*instruction, he will associate American concepts or objects with the foreign symbols” (R.Polizer, 1959:100-1).*

The learning and teaching of a language essentially concentrate on communication with an emphasis on communicative competence rather than on linguistic competence only. Good techniques and methods for teaching culture as well as applying it to foreign language teaching are not easy to be found and applied effectively. To help students (SS) use the language they can learn accurately and natively, teachers (Ts) should provide them with both linguistic and cultural input during the teaching and learning process. “If we teach language without teaching at the same time the culture in which it operates, we are teaching meaningless symbols or symbols to which the SS attach the wrong meaning; for unless he is warned, he receives cultural instruction, he will associate American concepts or objects with the foreign symbols” (R.Polizer, 1959:100-1).

In conclusion, the role of language teachers is essentially important, they are the ones help the learners get second language by instructing, encouraging, guiding, and explaining...

**\* This is useful activity for English teaching - role play activity.**

**Students:** The first year students of English Department in HPU.

**Aims:** In order to raise SS’ awareness of different levels of politeness in making requests.

**Time:** 10-15 minutes

**Instruction:** SS work in pairs, decide the best way of making request in following situations:

<b>Partner A (you are...)</b>	<b>Partner B (you are..)</b>
<b>1. A manager.</b> You don’t want to be disturbed for	<b>A secretary</b>

a while. Ask your secretaty to hold your calls.	
<b>2. An office manager.</b> Ask one of your clerks to turn down his/her radio.	<b>A clerk.</b>
<b>3. A secretary.</b> Ask your Boss to fix an oppointment with Mr. Tom of Toysha Co., Ltd.	<b>A secretary.</b>

#### 4. Concluding remarks.

In this case-study, there are many interesting major findings. We can find out the differences as well as some similarities in English and Vietnamese request forms which depend on occupational position, relationship, sex...

In dealing with request and politeness strategies used in making requests, it is necessary to point out that requests do translate across quite unrelated languages and cultures, but they do not, the translation gaps are due to cross-linguistic and cross-culture differences, English and Vietnamese have different ways expressing themselves and of makingrequest. Therefore, in order to avoid culture shock and communication breakdown cross-cultural interactants shld be equiped with more awareness of not only cross-linguistic, but also cross-cultural differences.

## PART THREE

### CONCLUSION

#### 1. Summary of the study

With the great help and encouragement of my supervisor, teachers, and my family, this graduation paper has been completed on time.

I have designed this paper into three parts in which the second part (the major part) consists of four chapters:

**Chapter one:** states the common knowledge on request forms and related definitions of culture, communication and intercultural communication.

**Chapter two:** focuses on study some parameters that influence the use of English and Vietnamese requests in communication at the office: English request forms & Vietnamese request forms.

**Chapter three:** studies the context that influences the use of Requests in communication at the office. In this chapter, I focus on solving the question “How to translate English requests into Vietnamese requests in real contexts”.

**Chapter four:** presents a seminar in Nam Trieu shipbuilding industry cooperation in Hai Phong city as a case-study. There are also the differences and some similarities in English and Vietnamese requests in terms of politeness in communication. In addition, the implication for ELT is also presented as reference material for teaching English.

I do expect that, this study will be helpful to whom who wants to learn about English and Vietnamese requests in communication at the office as well as people who feel interested English. It can be open to readers' useful ideas for further study.

However, with my limited knowledge, ability, and the restrict of time, there may have some mistakes and shortcoming, I hope to receive the sympathy and contribution from teachers and reader to make my graduation better.

Last but not least, I would like to express my deepest gratitude to my supervisor- Ms. Nguyen Thi Hoa, MA as well as my teachers in English department for their support and comments. My thanks also come to managers and staff in Nam Trieu shipbuilding industry corporation in Hai Phong city, and my family.

## **2. Suggested for further researches.**

- Requests and terms of reference in Vietnamese.
- The difference between Vietnamese and Chinese request forms.
- Request and response in English and Vietnamese.
- Request in communication at Hotel and Restaurant.